

UG8-O UNIGUARD SMOKE DETECTOR

Optical smoke detector with in-built service alarm for use in ventilation ducts
Free-rotation in any direction



TECHNICAL DATA

Supply voltage:	24V DC from the control unit
Detector type:	Optical
Operating current:	~ 0.04 mA
Service alarm current:	~ 10 mA (at 22V)
Alarm current:	~ 40 mA (at 22V)
Ambient temperature:	-20°C to +55°C
Humidity:	Max. 99% RH
Tested and approved:	Smoke detector according to EN 54-7
Smoke detector LED	
– Red:	Smoke alarm
– Green:	Service/contamination alarm
Material	
– Adaptor enclosure:	PC/ABS
– Venturi tube:	Aluminium
Protection class:	IP65

FEATURES

- Service alarm
- Automatic sensitivity adjustment
- Test hole on the cover
- Easy installation
- Flow indicator
- Simple service and maintenance
- Complete with pre-mounted cable entries

FUNCTION

The UG8 Uniguard has been developed to measure smoke in ventilation ducts and consists of a smoke detector and duct enclosure system, specially-designed for optimal airflow through the smoke detector.

The UG8 can be mounted on either side of the duct. The UG8 comes a rotating section that, together with your chosen Venturi tube, is mounted on the ventilation duct. It also has a “FLOW arrow” for easy installation in the correct direction for the airflow. The direction of the arrow should correspond with the direction of the airflow in the duct. The patent-pending detector enclosure with cable inputs can be rotated in any direction to suit the characteristics of the mounting location. Both the smoke detector chamber and connection chamber covers have snap locks for quick access.

EVC-PY-DA has an intelligent monitoring circuit that constantly checks and adjusts the sensitivity for optimum functionality throughout its service life. When the detector can no longer compensate for contamination and starts to approach a false alarm, a service alarm will be indicated.

The detector is fitted with a bayonet mount, making it easy to fit and remove. The UG8 can be used with Calectro's ST280 and ST580 Venturi tubes, as well as the extension tube ST-EXTEND.

BASIC PRINCIPLES OF PLACEMENT

In order for the airflow through the Uniguard to be representative of the airflow in the ventilation duct, the Uniguard should be placed as an airflow meter would be. See the installation guide supplied with the product.

You can also use national or local rules for mounting in accordance with “Methods for measuring airflow in ventilation installations”.

UG8-O UNIGUARD SMOKE DETECTOR

Optical smoke detector with in-built service alarm for use in ventilation ducts
Free-rotation in any direction



INSTALLATION

STx pipes made of aluminium can be cut in order to adjust them to the ventilation duct. Hole size \varnothing 38 mm. For insulated, round and small ducts, mounting brackets are used and in this case, the hole size is \varnothing 51 mm.

NB! For mounting outdoors, in non-insulated attics, etc., the detector should be isolated from the ambient air using insulated box, for example, a UG-COVER-75. In these circumstances, it should also be marked with an additional alarm indicator light LED-03. Install a sign indicating the presence of a concealed smoke detector.

MAINTENANCE

The detector has an intelligent control circuit. The circuit adjusts the sensitivity so the detector can function as best as possible for its entire lifetime. Once the control circuit has reached its maximum sensitivity compensation for contaminants and starts to reach a false alarm, a service alarm is indicated. The life of the smoke detector can be extended by cleaning the detector once a year using a vacuum cleaner.

AIRFLOW CONTROL

At the inlet, in the detector chamber, there is a flow switch. When the Uniguard Superflow is correctly mounted, the flow switch is pushed outwards by the air stream from the Venturi tube.

SIMPLE FUNCTION TEST

After set up, the smoke detector should be tested. The test, for example, can be carried out using our SOLO A5 test spray. Use the test hole in the cover. **Do not forget to replace the plastic plug after the test.**

CIRCUIT DIAGRAM

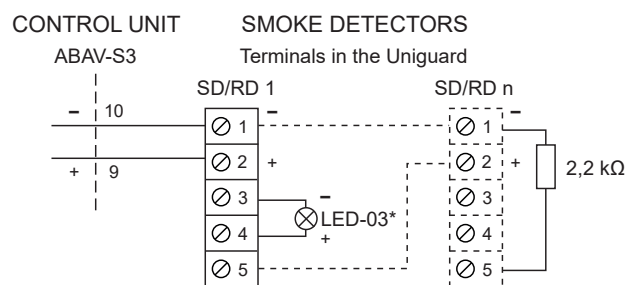

* Cable length of LED-03 max 3 m.

DIMENSIONS (mm)

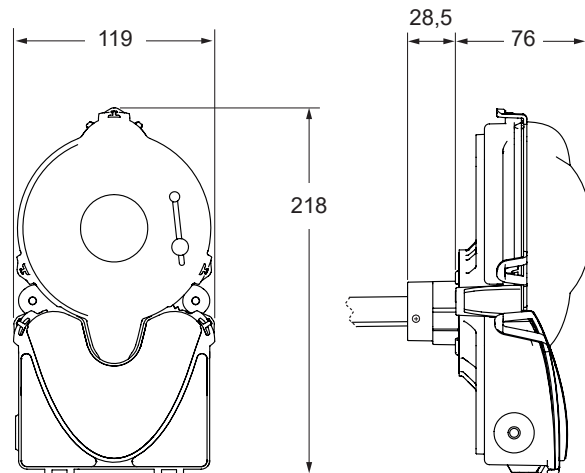

EXAMPLE OF ORDER

Item code	Designation
UG8-O	Uniguard, optical smoke detector

ACCESSORIES

Item code	Designation
UG-MB-8	Mounting bracket (for insulated/round ducts)
UG-COVER-75	Protective cover (for mounting outdoors, in non-insulated attics, etc.)
ST280*	Venturi tube, aluminium (length: 280 mm)
ST580*	Venturi tube, aluminium (length: 580 mm)
ST-EXTEND	Extension of STx Venturi tube, 1.06 m

* Venturi tube sold separately.